



SPECIFICATION
FOR
APPROVAL

深圳市銳創達電子有限公司

TAT ELECTRONICS CO. LTD.

CUSTOMER:

PART NUMBER: BMC9650S-0327

CUSTOMER PART NO.:

CUSTOMER	APPROVED	CHECKED
SIGNECTURE (Customer)	SIGNECTURE (Company)	

Add: 深圳市福田区八卦一路鹏基商务时空 1610

Tel:+86-755-8950 9282, 8950 9880, 2109 3136;

Fax:+86-755-6135 1661

Email: tatspeaker@tatelec.com; sales@tatelec.com;

[Http:// www.tatelec.com](http://www.tatelec.com)



Specification for Electro-Magnetic Buzzer		Update/22A01	Page 2 of 8
		Des.	Chk.
Model No.:	BMC9650S-0327	Yao	Lu
		2022.6.23	2022.6.23

变更记录

Change History list

版本 Version	变更描述 Change Description	核对 Checked	审核 Approved	日期 Date
22A01	首次发行	姚海明	陆协林	2022. 6. 23



Specification for Electro-Magnetic Buzzer		Update/22A01	Page 3 of 8
		Des. Yao	Chk. Lu
Model No.:	BMC9650S-0327	2022.6.23	2022.6.23

1 . Electrical Characteristics

VER .:0

Oscillation Frequency (KHz)	2.7 ± 0.3
Operating Voltage (VDC)	2 ~ 5
Rated Voltage (VDC)	3
Current Consumption (mA/max)	30 at Rated Voltage
Sound Pressure Level (dB/min)	80 at 10cm at Rated Voltage
Tone/Pulse Rate	Single
Operating Temperature (°C)	-30 ~ +85
Storage Temperature (°C)	-30 ~ +85

2 . Voltage/ Current / Sound Pressure

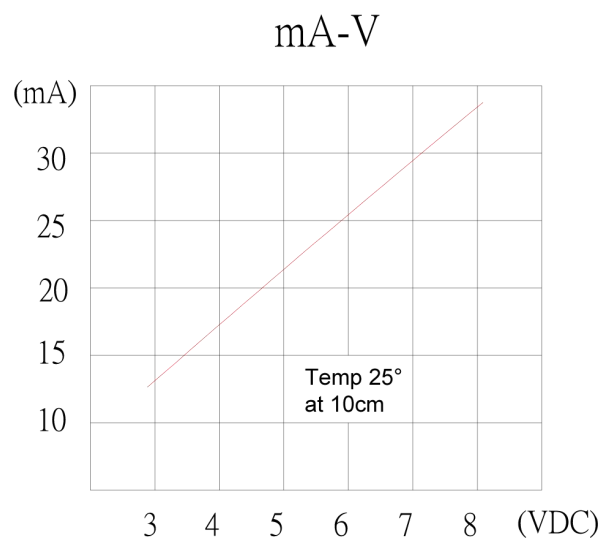
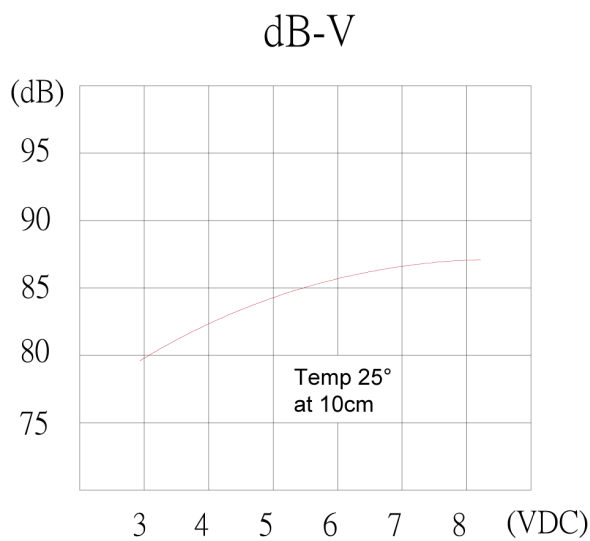



Specification for Electro-Magnetic Buzzer		Update/22A01	Page 4 of 8
		Des. Yao	Chk. Lu
Model No.:	BMC9650S-0327	2022.6.23	2022.6.23

3 . Dimensions and Material

3-1 Shape

蜂鸣器焊接方法 Buzzer Soldering process	Soldering Parameter		
	温度 Temp.(°C)	时间 Time(Sec.)	可焊接次数 Times
回流焊 Reflow soldering	245±15	180°C预热 40~70 秒 above 180°C time 40~70	3
★波峰焊 Wave soldering	255±5	4~6	2~3
★手工焊 Manual soldering	350±10	2~5	2~3
接插件			
带★号为推荐的焊接方法 Remark: ★ Instance Soldering Process			
外形图 (单位: 毫米) DIMENSIONS (UNIT: mm)			

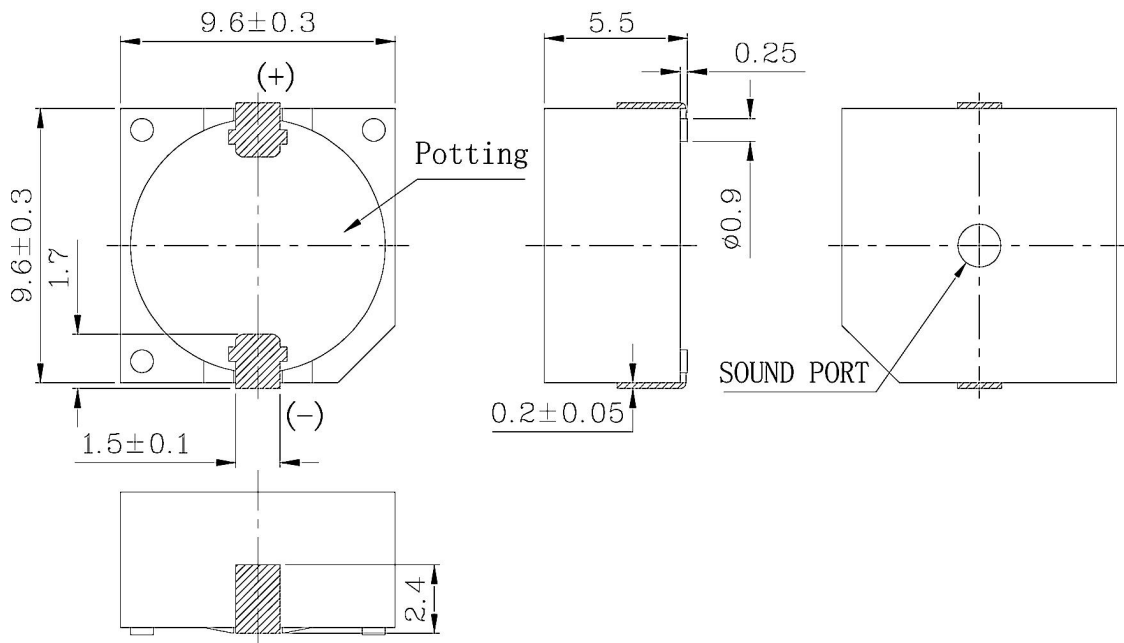

Tol : ± 0.3 Unit: mm



Specification for Electro-Magnetic Buzzer		Update/22A01	Page 5 of 8
		Des. Yao	Chk. Lu
Model No.:	BMC9650S-0327	2022.6.23	2022.6.23

3-2 Material

Housing	PPS plastic resin (Color : Black)
Leading Pin	Au Plated Brass
Weight (Gram)	1.5

4. TESTING METHOD

· Standard Measurement conditions

Temperature: $25 \pm 2^\circ\text{C}$ Humidity: 45-60%

· Acoustic Characteristics

The oscillation frequency, current consumption and sound pressure are measured by the measuring instruments shown below.

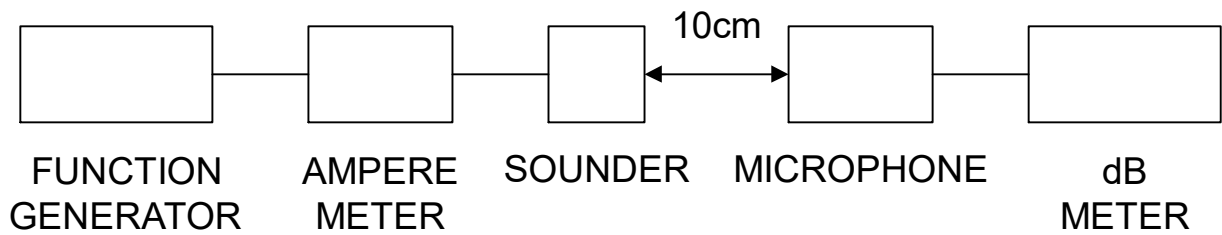

In the measuring test, buzzers is placed as follows:

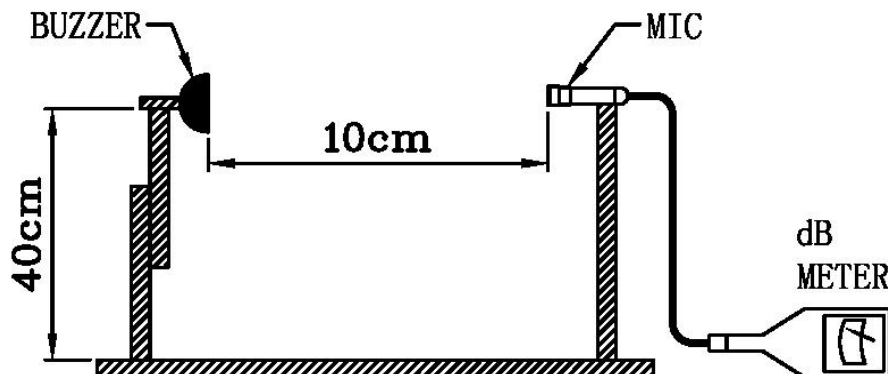



Specification for Electro-Magnetic Buzzer		Update/22A01	Page 6 of 8
		Des.	Chk.
Model No.:	BMC9650S-0327	Yao	Lu
		2022.6.23	2022.6.23

5.RELIABILITY



Specification for Electro-Magnetic Buzzer		Update/22A01	Page 7 of 8
		Des.	Chk.
Model No.:	BMC9650S-0327	Yao	Lu
		2022.6.23	2022.6.23

型号 Ppart No: BMC9650S-0327			
可靠性测试 RELIABLY TEST			
NO	项目 ITEM	测试条件 TESTING CONDITION	试验后要求 VARIANCE AFTER TEST
1	湿热 Humidity	蜂鸣器置于温度在 40 °C , 相对湿度在95%中, 保持 96 小时后, 试验后在常温下恢复 2 小时测试	Allowable variation of SPL after test: 10dB.
		40±5°C, 95(+2/-3)%RH, 96HRS	
2	高温测试 High temp.	蜂鸣器放置在+80±2°C中, 96 小时后测试性能指标	
		+80±2°C, 96HRS	
3	低温测试 Low temp.	将蜂鸣器放置在-30±2°C中, 96 小时后测试性能指 标	
		-30±2°C, 96HRS	
4	温度循环测试 Temperature Cycling	蜂鸣器在-20°C暴露 30min, 在60°C暴露 30min, 五次循环后, 试验后在常温下恢复 2 小时	
		-20±2°C, 30minutes room temp. 15 minutes +70±2°C, 30 minutes room temp. 15 minutes 5 cycles	
5	跌落 Drop test	将蜂鸣器放置在水平位置, 从 750mm 高度自由跌落到 10mm 硬木板上, 跌落 3 次后, 检 查外观并测量电性能	
		3 times from height of 75cm onto the surface of 10mm thick wooden board.	
6	振动 Vibration test	将蜂鸣器置于振幅为 1.5mm 的振动与 10 至 55Hz 的振 动频带施加到 3 个方向,每个方向上 2 小时。	
		After being applied vibration of amplitude of 1.5mm with 10 to 55 Hz band of vibration frequency to each of 3perpendicular directions for 2 hours .	
7	焊锡耐热性 Solder heat resistance	将产品针脚放置在 250±3°C的锡炉里, 持续 3 秒	
		The part leads (pins) shall be immersed in molten solder maintained at 250±10°C for a period of 3 seconds.	
8	插针强度测试 Terminal Strength Pulling Test	插针应承受 9.8N 拉力, 拉力时间 10 秒, 插针无松动和脱落等现象	
		The force of 9.8N(1.0kg) is applied to each terminal in axial direction for10 seconds. No visible damage and cutting off.	



Specification for Electro-Magnetic Buzzer		Update/22A01	Page 8 of 8
		Des.	Chk.
Model No.:	BMC9650S-0327	Yao	Lu
		2022.6.23	2022.6.23

6. PACKAGE METHOD

